

New items may not be available in QOE until update.
These can be added using \$\$SQIACC using the price obtained from customer service.

NOTES

Arched Raised Panel Valance

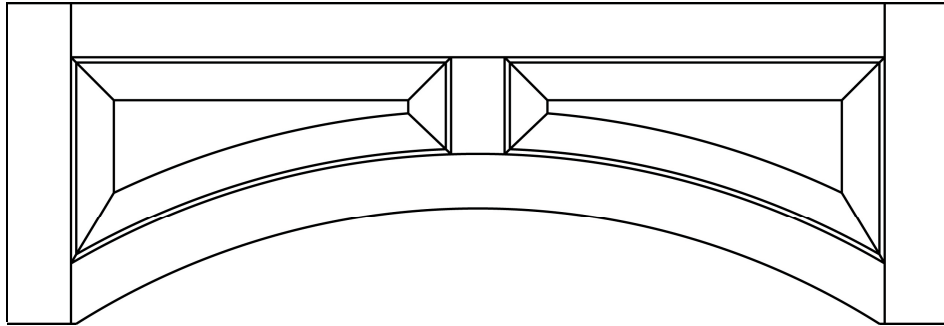

Standard Notes:

- Available in 3” width increments from 30” to 72” wide.
- Minimum height is 12 ½”, maximum height is 24”
- Stiles are 2 ¾”, rails are 2 5/16”, and center upright is 2 ½”
- The rise is always 4 ½”, regardless of width.
- Outside edge is a square machine edge.
- Center panel grain is horizontal.

*Other sizes and configurations are available as non-standard items and require a custom quote. \$\$QIRPV

Standard matches are available for the following door styles:

- Alexandria**
- Richmond**
- Springfield**
- Providence**
- Columbus**
- Annapolis**
- Augusta**
- Washington**
- Olympia**
- Quaker**
- Amesbury**

RPV30
RPV33
RPV36
RPV39
RPV42
RPV45
RPV48
RPV51
RPV54
RPV57
RPV60
RPV63
RPV66
RPV69
RPV72

Arched Raised Panel Valance Box

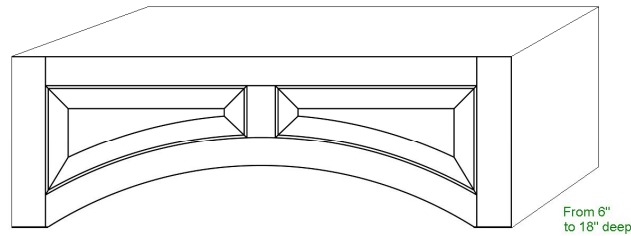

Standard Notes:

- Available in 3" width increments from 30" to 72" wide.
- Minimum height is 12 1/2", maximum height is 24"
- Stiles are 2 3/4", rails are 2 5/16", and center upright is 2 1/2"
- The rise is always 4 1/2", regardless of width.
- Outside edge is a square machine edge.
- Center panel grain is horizontal.
- Depth is to be specified from 6" to 18" deep.
- Finished Interior and Flush Finished Sides are included.

*Other sizes and configurations are available as non-standard items and require a custom quote. \$SQIRPVB

Standard matches are available for the following door styles:

- Alexandria
- Richmond
- Springfield
- Providence
- Columbus
- Annapolis
- Augusta
- Washington
- Olympia
- Quaker
- Amesbury

RPVB30
RPVB33
RPVB36
RPVB39
RPVB42
RPVB45
RPVB48
RPVB51
RPVB54
RPVB57
RPVB60
RPVB63
RPVB66
RPVB69
RPVB72

Wall Filler Columns

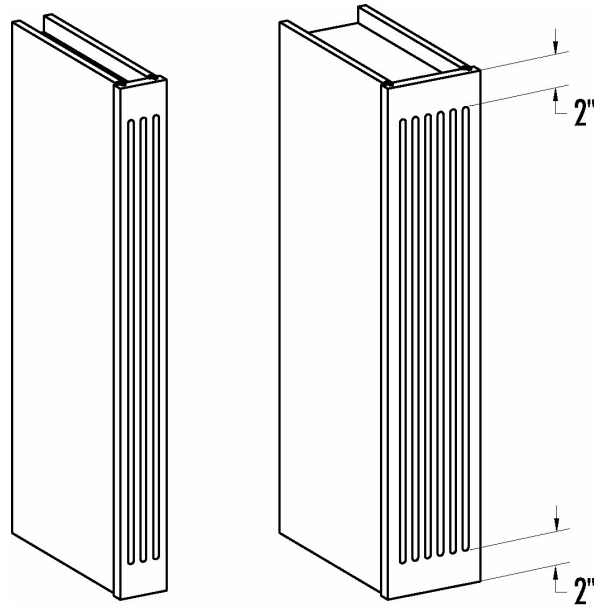

Slab Face (**WFC-SF**) or
Fluted Face (**WFC-FF**)

Available with:

1 1/2" to 9" Wide Face
12" to 120" Height
6" to 48" Depth

All Finished Side Options Available

Pilaster Door Face (**WFC-FPD**)

Available with:

3 3/4" to 24" Wide Face
5" to 96" Height
6" to 48" Depth

All Finished Side Options Available

Base Filler Columns

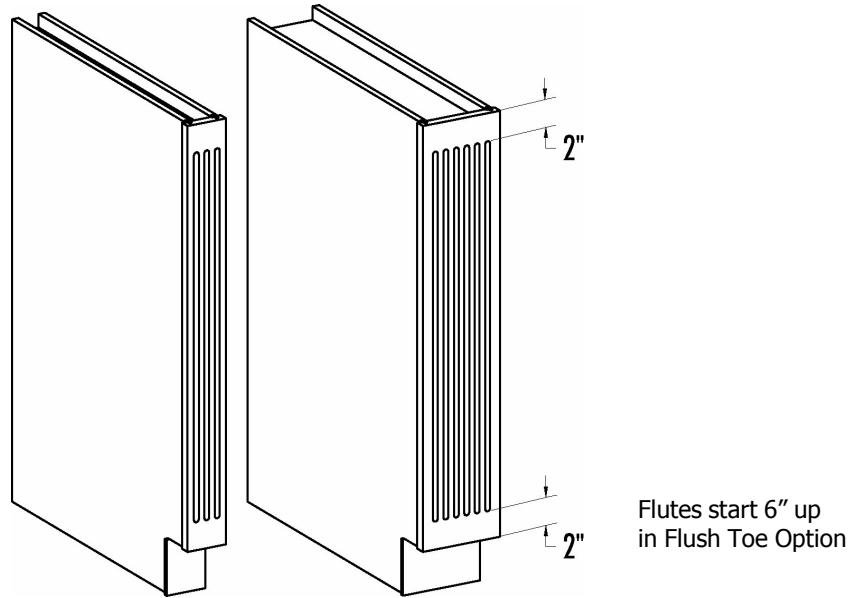

Slab Face (**BFC-SF**) or
Fluted Face (**BFC-FF**)

Available with:

1 1/2" to 9" Wide Face
12" to 120" Height
6" to 48" Depth

All Finished Side Options Available
Flush or Recessed toekick

Pilaster Door Face (**BFC-FPD**)

Available with:

3 3/4" to 24" Wide Face
5" to 96" Height
6" to 48" Depth

All Finished Side Options Available
Flush or Recessed toekick

Tall Filler Columns

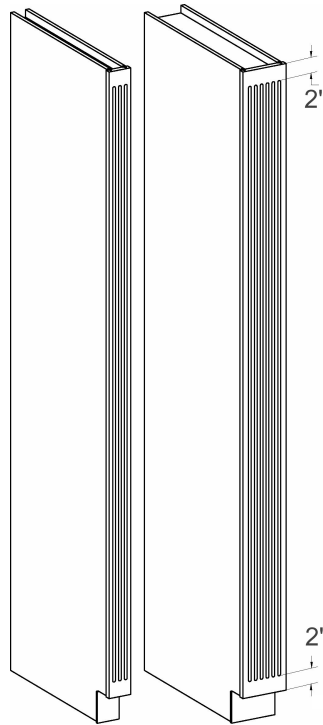

Flutes start 6" up
in Flush Toe Option

Slab Face (TFC-SF) or
Fluted Face (TFC-FF)

Available with:

1 1/2" to 9" Wide Face
12" to 120" Height
6" to 48" Depth

All Finished Side Options Available
Flush or Recessed toekick

Pilaster Door Face (TFC-FPD)

Available with:

3 3/4" to 24" Wide Face
5" to 96" Height
6" to 48" Depth

All Finished Side Options Available
Flush or Recessed toekick

Refrigerator End Panels
 Dishwasher End Panels
 Wall End Panels

Available with:

- Standard – No Toekick
- Standard – Flush Finished Side
- *Specify Side
- Toekick Option
- Beaded Side Option
- Wainscot Side Option
- Use Fluted Column for fluted face
- Interior finished return set flush 6” deep.

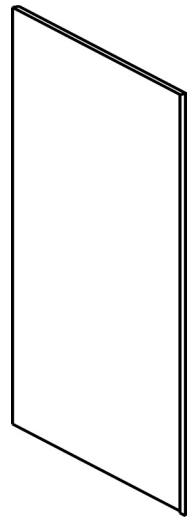
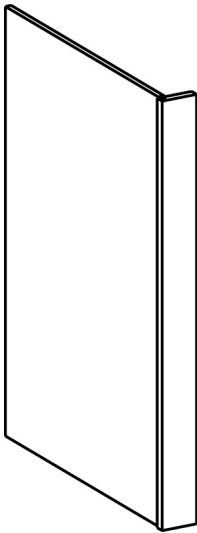

REP / DWEP / WEP

Solid Front Face

Available

7/8” to 9” Width

12” to 120” High

6” to 30” Deep

REPF / DWEPF / WEPF

2mm Edgebanded Front,
 bottom and top edge

Available

3/4 “ Width

12” to 120” High

6” to 30” Deep

Short-Grain Panels

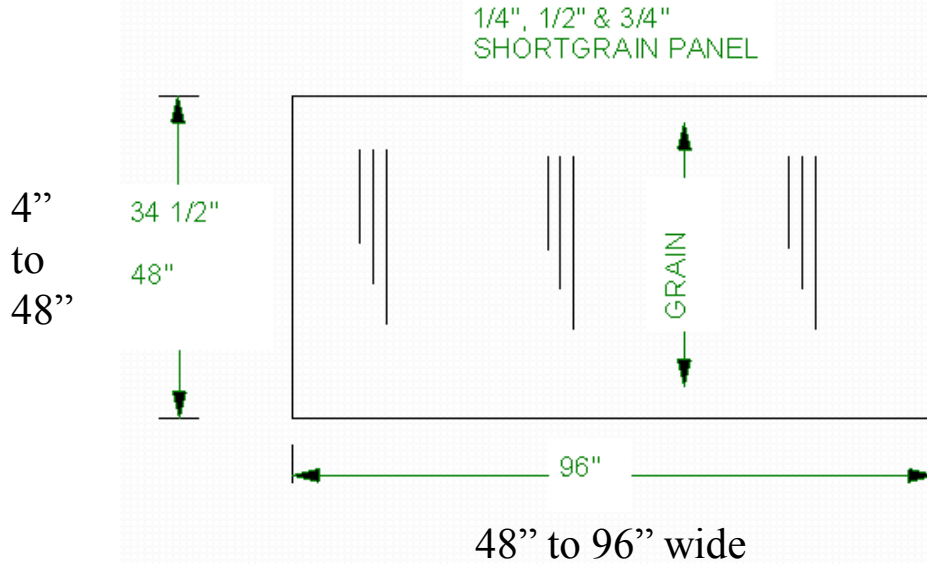

Available as listed:

1/4"	1/2"	3/4"
	Option: Finished Back	Option: Finished Back Option: Band and Finish Edges
FP.25S	FP.5S	FP.75S

Red Oak
Maple
Paint Grade
Cherry
White Birch
Pecan / Hickory
Walnut

Red Oak
Hard Maple
Paint Grade
Cherry
Red Birch
White Birch
Pecan / Hickory

Red Oak
Hard Maple
Paint Grade
Cherry
White Birch

1/4", 1/2" & 3/4" Panel
 1/4" Beaded Panel 1 1/2" On Center

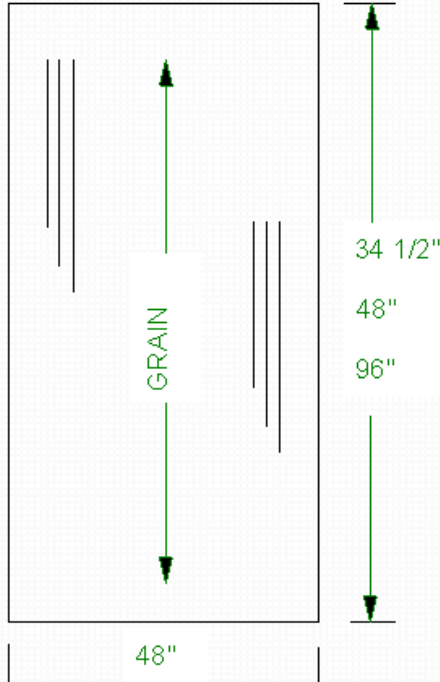

Long-Grain Panels

3" to 48" Wide

3" to 96" High

1/4"

1/2"

3/4"

Option: Finished Back

Option: Finished Back
 Option: Band and Finish Edges

1/4" Beaded Panel-
 1-1/2" O.C.

FP.25	FP.5	FP.75	FP.25B
--------------	-------------	--------------	---------------

Red Oak
 Hard Maple
 Paint Grade
 Cherry
 Red Birch
 White Birch
 Pecan / Hickory
 Walnut
 Alder
 Anigre
 Aromatic Cedar
 Mahogany
 Clear Pine
 Knotty Pine
 Qtr Sawn Red Oak
 Rift Cut White Oak
 Lyptus

Red Oak
 Hard Maple
 Paint Grade
 Cherry
 Red Birch
 White Birch
 Pecan / Hickory
 Walnut
 Mahogany
 Clear Pine
 Knotty Pine
 Qtr Sawn Red Oak
 Rift Cut White Oak

Red Oak
 Hard Maple
 Paint Grade
 Cherry
 Red Birch
 White Birch
 Pecan / Hickory
 Walnut
 Bamboo
 Alder
 Anigre
 Mahogany
 Clear Pine
 Knotty Pine
 Qtr Sawn Red Oak
 Rift Cut White Oak
 Lyptus
 Wenge
 Zebrawood
 Macassar Ebony
 Birdseye Maple

Red Oak
 Hard Maple
 Paint Grade
 Cherry
 White Birch

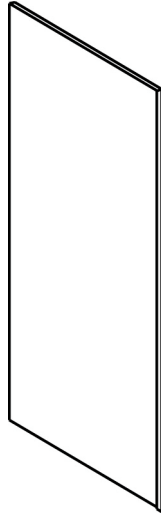

Finished Skins

1/8" or 1/4"
Depending on wood species

Available in :

- Red Oak
- Hard Maple
- Paint Grade
- Cherry
- Red Birch
- White Birch
- Pecan / Hickory
- Bamboo
- Alder
- Anigre
- Knotty Pine
- Lyptus
- Wenge
- Zebrawood
- Macassar Ebony
- Birdseye Maple
- Walnut

SKINBASE
SKINTALL84
SKINTALL96
SKINVANITY
SKINWALL30
SKINWALL42
SKINWALL54
SKINWALL65

Wainscot Panels

A Wainscot Panel is a series of doors built together.

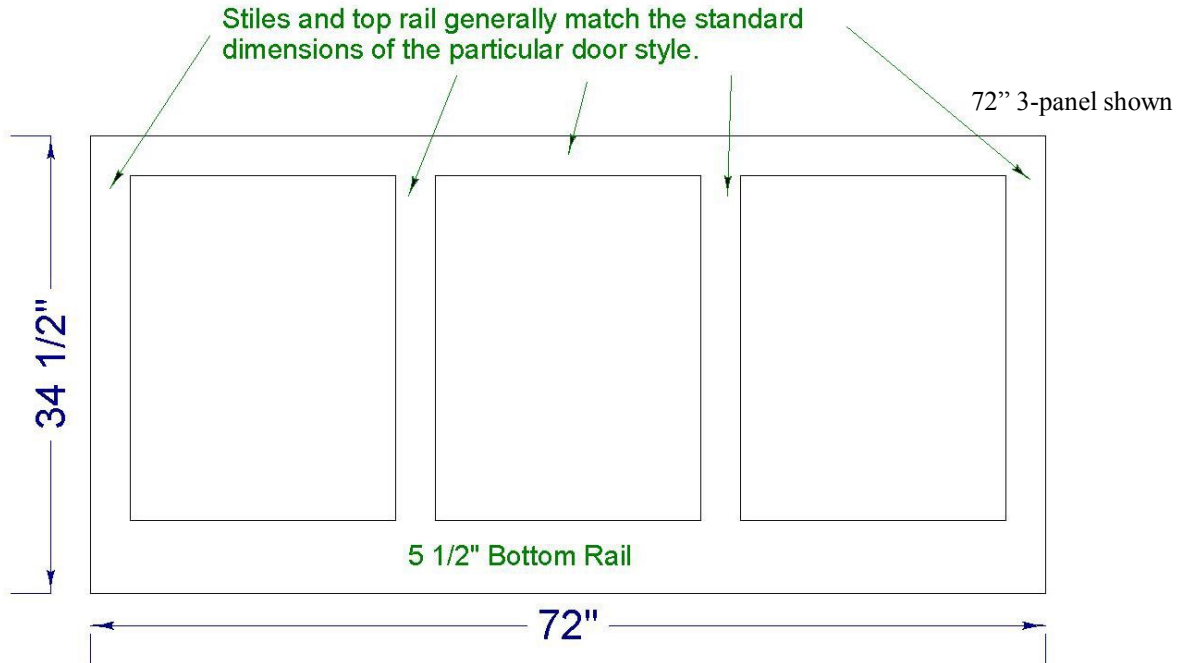

INTEGRAL		FRAME & DOOR
WSCTA-W	1 Panel	WSCTA-F&DW
WSCTB-W	2 Panel	WSCTB-F&DW
WSCTC-W	3 Panel	WSCTC-F&DW
WSCTD-W	4 Panel	WSCTD-F&DW
WSCTE-W	5 Panel	WSCTE-F&DW
WSCTF-W	6 Panel	WSCTF-F&DW
WSCTG-W	7 Panel	WSCTG-F&DW

Wainscot Panel Notes:

- Please consult the Door Manual to verify that the particular door style is available as a Wainscot Panel, all Mortise & Tenon styles are available..
- The sizes of the stiles and rails can be changed, but may increase the cost. Please request a quote.
- Standard pricing includes stiles and rails up to 8 3/4" in width, and overall panel size may not exceed 50" in both width and height. 50" can be exceeded in one direction, up to 119".
- Stiles and rails over 2 5/16" wide may utilize framing material containing one or more glue joints.
- Dimensioned drawings are preferred with a quote request, and order, to ensure correct price, and order entry.
- Finished Wainscot panels will have the face and all exterior edges stained and top-coated. The back of the panel will receive only a clear sealer coat unless the finished back option is selected.

Solid Wood Column Covers

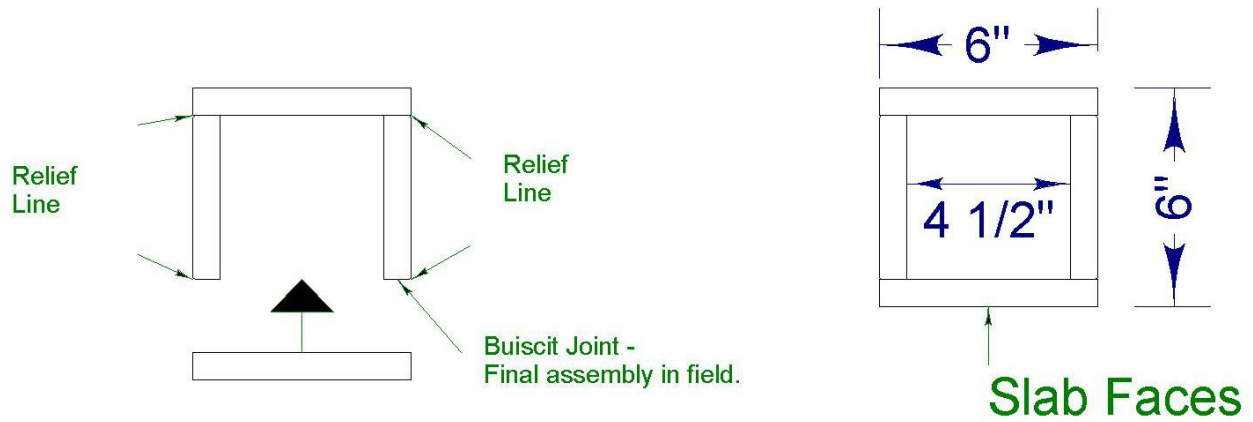

COLUMN-SW	Solid Wood Column Cover 3" to 6" Outside Dimension 12" to 120" High
COLUMN-PLY	Plywood Column Cover 6" to 12" Outside Dimension 12" to 120" High

COLUMNS WITH FLUTED FACES

COLUMN-FSW	Fluted Wood Column Cover 3" to 6" Outside Dimension 12" to 120" High
-------------------	--

Wainscot Column Covers Pilaster Door Column Covers

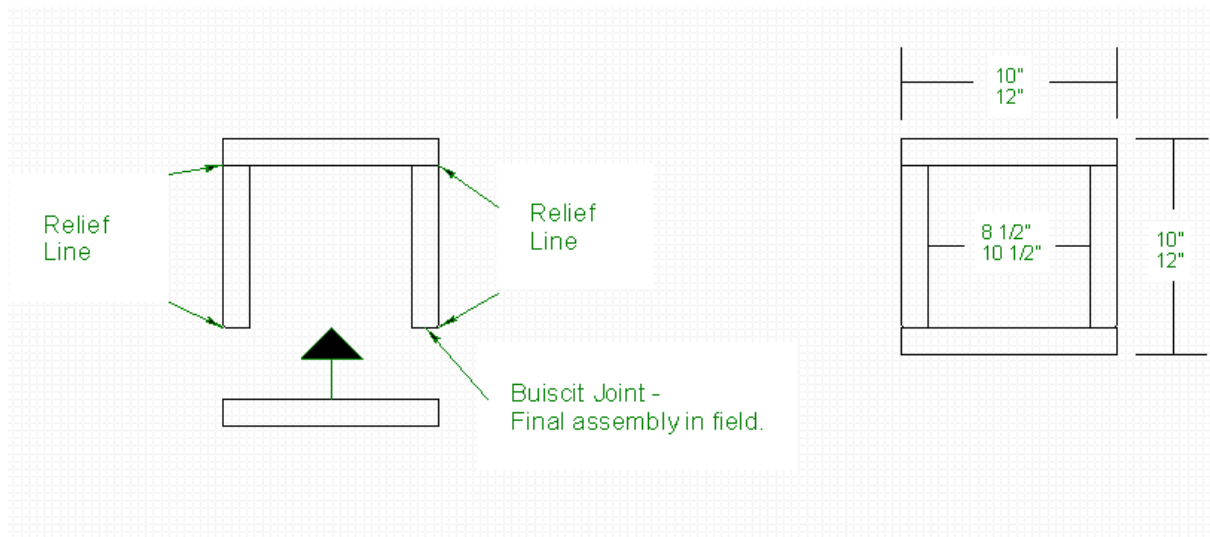

- Integral Wainscot only.
- Available on Mortise & Tenon Door Styles Only.

COLUMN-WA	1 Panel Wainscot Column Cover 8" to 12" Outside Dimension 12" to 96" High
COLUMN-WB	2 Panel Wainscot Column Cover 8" to 12" Outside Dimension
COLUMN-WC	3 Panel Wainscot Column Cover 8" to 12" Outside Dimension

COLUMN-PD	Pilaster Door Column Cover 3 3/4" to 12" Outside Dimension 5" to 96" High)
------------------	--

Framed Appliance Panel on 1/4" Panel

Reveal varies as per appliance specs.

Amesbury Door Shown

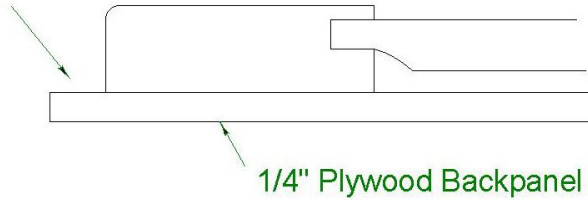

This is a cross-section of a framed appliance panel. The 1/4" plywood panel is meant to be inserted into a metal frame that is provided with the appliance. The size of the overall panel will vary. Please consult the spec sheets for the particular appliance before ordering.

Please use the supplemental order form along with including the item on the Panel Order Sheet. Please include the make & model # of the appliance. Grille Panels are not included in the standard front panel price. You must order it separately. If your refrigerator falls between the available sizes, use the next larger size for pricing.

REF-FAP	REFRIGERATOR DOOR Framed Appliance Panel
FZR-FAP	FREEZER DOOR Framed Appliance Panel
D/W-FAP	DISHWASHED DOOR Framed Appliance Panel
GRILLE-SDF-FAP	GRILLE (Match SDF) Framed Appliance Panel
GRILLE-LDF-FAP	GRILLE (Match LDF) Framed Appliance Panel
WC-FAP	WINE COOLER DOOR Framed Appliance Panel
IM-FAP	ICE MAKER DOOR Framed Appliance Panel
UCREF-FAP	UNDER COUNTER REF DOOR Framed Appliance Panel
WD-FAP	WARMING DRAWER (Match LDF) Framed Appliance Panel
DWD-FAP	DISH WASHER DRAWER (Match LDF) Framed Appliance Panel
REFD-FAP	REF DRAWER (Match LDF) Framed Appliance Panel

Full Overlay Appliance Panels

Amesbury Door Shown

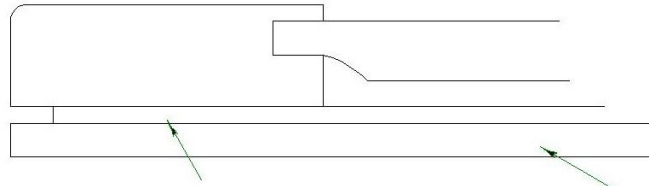

Spacer Panels as required per appliance specs

1/4" Plywood Backpanel

This is a cross-section of a full overlay appliance panel.

The 1/4" plywood panel is meant to be inserted into a metal frame that is provided with the appliance.

The door front extends to cover the face of the metal frame.

The size of the overall panel, spacer panel, and door front will vary. Please consult the spec sheets for the particular appliance before ordering.

Please use the supplemental order form along with including the item on the Panel Order Sheet.

Please include the make & model # of the appliance.

Grille Panels are not included in the standard front panel price. You must order it separately.

If your refrigerator falls between the available sizes, use the next larger size for pricing.

REF-FOAP	REFRIGERATOR DOOR Full Overlay Panel
FZR-FOAP	FREEZER DOOR Full Overlay Panel
D/W-FOAP	DISHWASHED DOOR Full Overlay Panel
GRILLE-SDF-FOAP	GRILLE (Match SDF) Full Overlay Panel
GRILLE-LDF-FOAP	GRILLE (Match LDF) Full Overlay Panel
WC-FOAP	WINE COOLER DOOR Full Overlay Panel
IM-FOAP	ICE MAKER DOOR Full Overlay Panel
UCREF-FAOP	UNDER COUNTER REF DOOR Full Overlay Panel
WD-FOAP	WARMING DRAWER (Match LDF) Full Overlay Panel
DWD-FOAP	DISH WASHER DRAWER (Match LDF) Full Overlay Panel
REFD-FOAP	REF DRAWER (Match LDF) Full Overlay Panel

Integrated Appliance Panels

Amesbury Door Shown

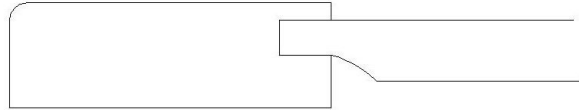

This is a crossection of an integrated appliance panel.

The ¾” door is to be fastened to the face of the appliance using fasteners provided by the appliance manufacturer. Decorative hardware must be used.

The size of the door front will vary. Please consult the spec sheets for the particular appliance before ordering.

Please use the supplemental order form along with including the item on the Panel Order Sheet.

Please include the make & model # of the appliance.

Grille Panels are not included in the standard front panel price. You must order it separately.

If your refrigerator falls between the available sizes, use the next larger size for pricing.

REF-IAP	REFRIGERATOR DOOR Integrated Door Only
FZR-IAP	FREEZER DOOR Integrated Door Only
D/W-IAP	DISHWASHED DOOR Integrated Door Only
GRILLE-SDF-IAP	GRILLE (Match SDF) Integrated Drawer Front Only
GRILLE-LDF-IAP	GRILLE (Match LDF) Integrated Drawer Front Only
WC-IAP	WINE COOLER DOOR Integrated Door Only
IM-IAP	ICE MAKER DOOR Integrated Door Only
UCREF-IAP	UNDER COUNTER REF DOOR Integrated Door Only
WD-IAP	WARMING DRAWER (Match LDF) Integrated Drawer Front Only
DWD-IAP	DISH WASHER DRAWER (Match LDF) Integrated Drawer Front Only
REFD-IAP	REF DRAWER (Match LDF) Integrated Drawer Front Only

Integrated Frame & Door Appliance Panels

Amesbury Door Shown



1/4" BEADED INSET APPLICATION SHOWN

Panels size as required
per appliance specs

This is a cross-section of a Frame & Door integrated appliance panel. The 3/4" door is to be fastened to the face of the appliance using fasteners provided by the appliance manufacturer. In some cases a particular appliance has attachment points that fall in the joint between the frame and door. In this case, we suggest ordering the panel with an increased framing size. Please be sure to check the spec sheets to determine if you need to make changes.

Decorative hardware must be used.

The size of the door front will vary. Please consult the spec sheets for the particular appliance before ordering.

Please use the supplemental order form along with including the item on the Panel Order Sheet.

Please include the make & model # of the appliance.

Grille Panels are not included in the standard front panel price. You must order it separately.

If your refrigerator falls between the available sizes, use the next larger size for pricing.

Beaded Inset style is shown. Other styles using a frame & door are Plain Inset, and 3/8" Inset.

Back of panel is finished 1" in from all edges. Please be sure to size your panel accordingly or unfinished surfaces will be exposed. Extending the panel up on a Sub-Zero 700 series will reveal the scab and an unfinished surface. If you need to extend the top of the panel, we suggest using a plain integrated appliance panel, not an integrated frame & door.

REF-IFDAP	REFRIGERATOR DOOR Integrated Frame & Door
FZR-IFDAP	FREEZER DOOR Integrated Frame & Door
D/W-IFDAP	DISHWASHED DOOR Integrated Frame & Door
GRILLE-SDF-IFDAP	GRILLE (Match SDF) Integrated Frame & Drawer Front
GRILLE-LDF-IFDAP	GRILLE (Match LDF) Integrated Frame & Drawer Front
WC-IFDAP	WINE COOLER DOOR Integrated Frame & Door
IM-IFDAP	ICE MAKER DOOR Integrated Frame & Door
UCREF-IFDAP	UNDER COUNTER REF DOOR Integrated Frame & Door
WD-IFDAP	WARMING DRAWER (Match LDF) Integrated Frame & Drawer Front
DWD-IFDAP	DISH WASHER DRAWER (Match LDF) Integrated Frame & Drawer Front
REFD-IFDAP	REF DRAWER (Match LDF) Integrated Frame & Drawer Front

Single Doors and Drawer Fronts

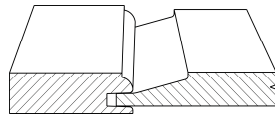
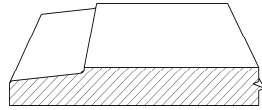
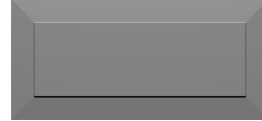
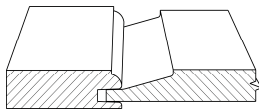
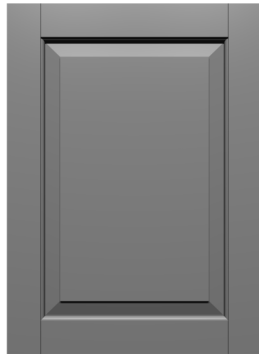

Doors Available:
7 1/2" to 26" Wide

See Below for Available Heights

Drawers Available:
7 1/2" to 48" Wide

See Below for Available Heights

DOOR-SP	SINGLE PANEL DOOR - 8" to 48" High
DOOR-DP	DOUBLE PANEL DOOR - 36" to 83" High
DRAWERHEAD-SDF	MATCH SMALL DRAWER HEAD - 4" to 12" High
DRAWERHEAD-LDF	MATCH LARGE DRAWER HEAD - 6" to 18" High
DRAWERHEAD-SLAB	SLAB DRAWER HEAD - 4" to 48" High, 96" long

Door and Drawer Front Notes:

- The doors will not be prepped for hinges.
- If you desire hinges, or want the door prepped for hinges, select in hinge drop down.
- Doors and Drawer Fronts are finished front, back, and 4 edges.

SHELVES

To order additional shelves, first select the type of shelf you want.

SHELFPB	¾" Particle Board Shelf
SHELFW-NF	¾" Plywood Shelf Natural Finish
SHELFW-MCF	¾" Plywood Shelf – Match Cabinet Finish

WIDTH	12" to 96"
THICKNESS	¾"
DEPTH	6" TO 30" Deep

Shelf Notes:

- Shelves will include the necessary shelf pins.
- Particle Board and Veneer (plywood) shelves are ¾".

Wood Countertops

To order a Wood Countertop, first make a dimensioned drawing.

WOODTOP-S	STRAIGHT
WOODTOP-L	“L” SHAPED
WOODTOP-D	“L” SHAPED W/ INSIDE DIAGONAL
WOODTOP-U	“U” SHAPED

AVAILABLE SIZES	6” TO 96” IN EITHER DIRECTION
-----------------	-------------------------------

Wood Countertop Notes:

- Wood Countertops are constructed from $\frac{3}{4}$ ” thick fiber core veneer plywood.
- The top has a second $\frac{3}{4}$ ” strip for build-up, and a $\frac{3}{4}$ ” x $1\frac{1}{2}$ ” solid wood nose.
- Please submit a drawing and indicate the grain direction, finished edges, and dimensions.
- Countertops over 48 x 96 will need a seam.
- Wood countertop shipping via common carrier may incur additional charges.
- Some wood countertops may be too large to ship via common carrier.

VENEERS



- All Veneers are approximately 1/32” thick (0.794 mm)
- One end and one side of veneer sheet is guaranteed to be free from physical damage.
- Wood back veneers have a cross grain wood backer.
- Poly back veneers are applied to a polymer resin impregnated membrane. They contain no added urea formaldehyde (NAUF), are rigid yet pliable and provide excellent moisture resistance.
- Wood back and poly back veneers are available with their applicable backer or a pressure sensitive adhesive (PSA). PSA veneers have a pre-glued adhesive layer protected by a peel coat covering that must be removed prior to application.
- Veneers are not guaranteed to perfectly match solid wood doors. Veneer is sliced from premium material; color and grain match will be more uniform than solid wood doors. Hickory veneers may contain mineral streaks and peck marks.
- Proper surface conditions and preparation is essential to successful application and performance of veneered surfaces.
 - Per manufacturer’s recommendations, veneers of all backer types should be placed flat and allowed to acclimate 48 hours before installation.
 - Pressure sensitive veneers should not be applied to bare wood, or surfaces covered with sanding sealers, high pressure laminates, melamine, or other plastic materials.
 - Wood back and poly back veneers are best applied with roller grade adhesives. Sufficient adhesive coverage on both the veneer and substrate surface will ensure proper adhesion and performance.
- Wellsford Cabinetry is not liable for product failure due to improper surface preparation, adhesive selection or installation technique.
- All veneers are available finished or unfinished.

PSA Wood Back

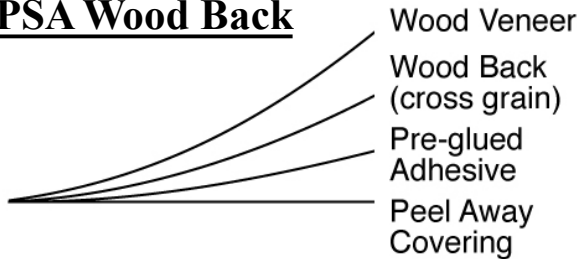

Poly Back

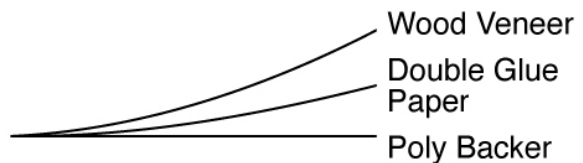

Wood Back

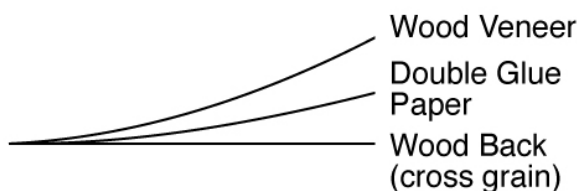

PSA Poly Back

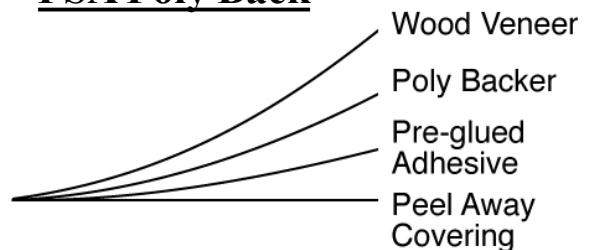

Continued on next page

VENEERS CONT.



Pricing codes are as shown in the chart below. Not all veneers are available in all sizes. Presence of code indicates availability. Veneers are shipped in sizes indicated. Cut to size not available. In most cases, veneers will be rolled for shipment.

Specie	24" x 96"		48-1/2" x 97"	
	PSA Wood Back	PSA Poly Back	Wood* Back	Poly Back
Alder	PWBALDER	PPBALDER	WBALDER	PBALDER
Anigre Bamboo			WBBAMBOO	PBBAMBOO
Birch, Red	PWBREDBIRCH	PPBREDBIRCH	WBREDBIRCH	PBREDBIRCH
Birch, White	PWBWHITEBIRCH*	PPBWHITEBIRCH	WBWHITEBIRCH*	PBWHITEBIRCH
Birdseye Maple			WBBIRDSEYE	PBBIRDSEYE
Cherry	PWBCHERRY*	PPBCHERRY	WBCHERRY*	PBCHERRY
Hickory	PWBHICKORY	PPBHICKORY	WBHICKORY	PBHICKORY
Lyptus	PWBLYPTUS	PPBLYPTUS	WBLYPTUS	PBLYPTUS
Macassar Ebony			WBMACASSAR	PBMACASSAR
Maple, Hard	PWBMAPLE*	PPBMAPLE	WBMAPLE**	PBMAPLE
Oak, Red	PWBREDOAK*	PPBREDOAK	WBREDOAK*	PBREDOAK
Oak, White	PWBWHITEOAK	PPBWHITEOAK	WBWHITEOAK	PBWHITEOAK
Pine, Knotty	PWBPINE	PPBPINE	WBPINE	PBPINE
Quarter Sawn White Oak	PWBQTROAK	PPBQTROAK	WBQTROAK	PBQTROAK
Walnut	PWBWALNUT	PPBWALNUT	WBWALNUT	PBWALNUT
Wenge			WBWENGE	PBWENGE
Zebrawood			WBZEBRA	PBZEBRA



Stock Item



Custom Item - Longer lead-time

* Available with colourtone finishes

** When ordered with colourtone finish, phenolic back veneer will be substituted.